

Bandpass Combiner Principles and Theory of Operation

Today more than ever the necessity of highly efficient and reliable combining systems has resulted in Bandpass combiners of two major topologies: Constant Impedance commonly called 'balanced' and Starpoint commonly called 'branch' combiners. I will reverse the order and first discuss the Starpoint topology, the schematic for a simple two channel is displayed in Figure 1.

Starpoint Schematic

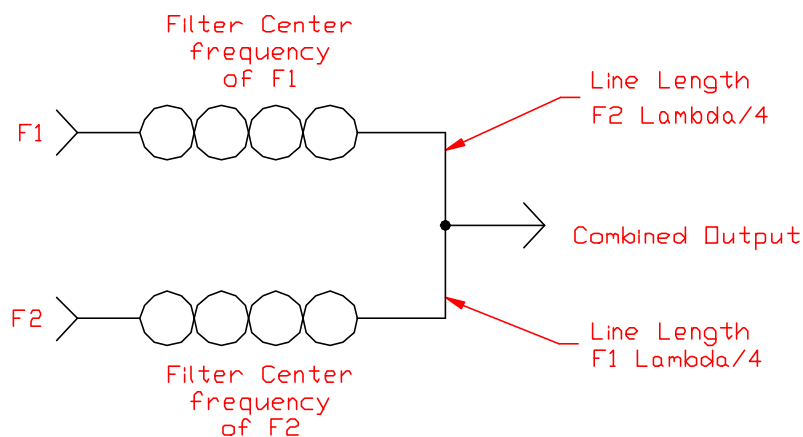

Figure 1

Starpoint combiners are most often used for simpler combining applications. In theory an infinite number of frequencies can be starpointed, however in application it is generally limited to a maximum of five or six channels with the bulk of the combiners of this type being two and three channel. The luxury of an inexpensive system with fairly conservative size considerations is one of the highlights of the Branch Combiner. This is due to the minimum number of components used in their construction. At this point one might wonder why all combiners are not Starpoint, after all they use bandpass filters, their inexpensive and do not require huge amounts of real estate to set them up. The downside is they do not offer the same level of performance as a Constant Impedance combiner. The isolation of a Starpoint is limited to the rejection of the filters used in the system. If one of the filters shown in Figure 1 is centered at F2 and has a rejection level of 30 dB at frequency F1 then the isolation of F1 to F2 is 30 dB. If the other filter is centered at F1 and has a rejection level of 38 dB at frequency F2 then the isolation of F2 to F1 is 38 dB. The Insertion Loss and Group Delay performance of a Starpoint Combiner will mimic that of the filters. The point here is that the system performance is a direct reflection of the filter performance, high quality, high power filters must be used and even these may not be enough.

When a higher level of performance is desired a Constant Impedance Bandpass Combiner is used. They are usually built in the format of one module per channel with each module consisting of ; two bandpass filters, two 3-dB Hybrid couplers and a dummy load, the schematic of single module is displayed in Figure 2.

Constant Impedance Schematic

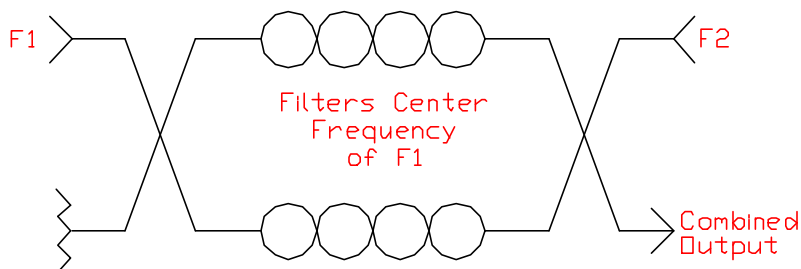

Figure 2

As expected the principles of operation for this type of combiner are somewhat more complicated than that of the Starpoint Combiner. From Figure 2 it can be seen that both filters are centered at frequency F1 with one port of each 3-dB Hybrid connected in a symmetric manner to the filters inputs and outputs. The F1 signal is split by the first 3-dB hybrid, passed through the filters, combined by the second 3-dB Hybrid and finally emitted at the 'Combined Output' port. The F2 signal is split by the second 3-dB Hybrid, reflected back by the filters, combined by the second 3-dB Hybrid and emitted from the 'Combined Output' port. This is illustrated in Figure 3.

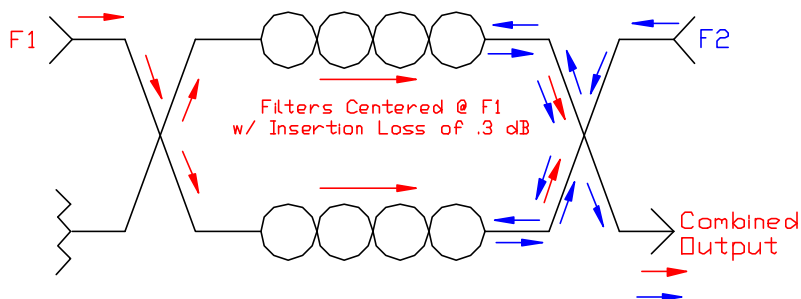

Figure 3

The greatest benefit of using a Balanced combiner is the extra isolation provided through 3-dB Hybrids. The theory of operation of these devices is beyond the scope of this discussion. Figure 4 shows the basic isolation properties of a 3-dB Hybrid when used as a power combiner.

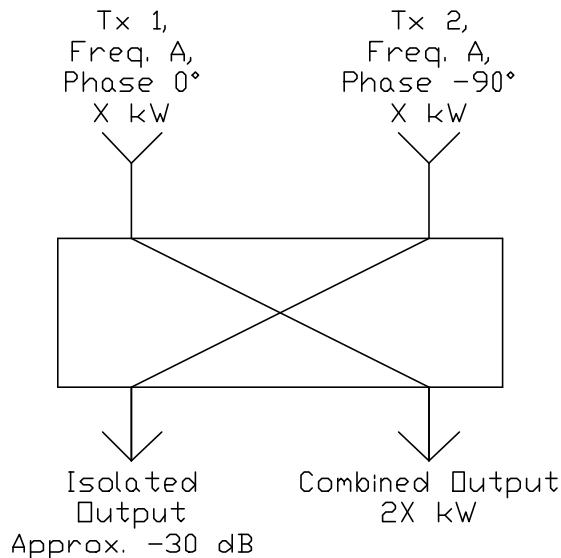

Figure 4

The limitations of this device are that it will only combine signals of the same frequency and power level. Back to the subject of frequency combiners. The isolated port of the 3-dB Hybrid provides the extra isolation that makes the balanced combiner so valuable. Figure 5 displays the isolation characteristic of a single combiner module. The frequency of the signals at the Narrowband input is F1 and the Wideband input is F2. F2 experiences the summed isolation of the filters tuned at F1 and the isolation of the F1 input 3-dB Hybrid.

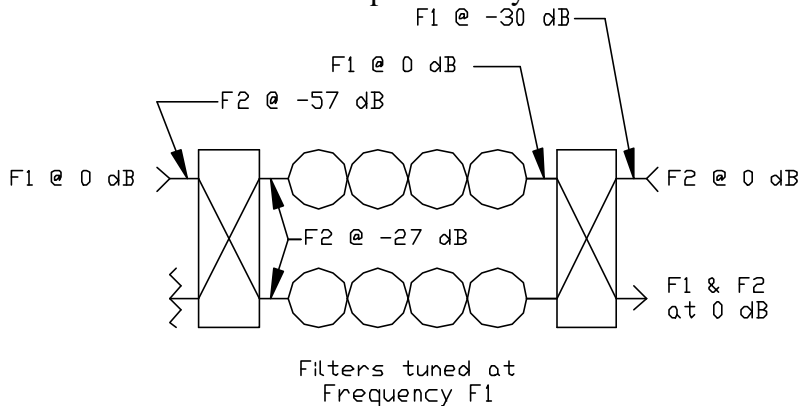

Figure 5

F1 passes through the filters and is steered towards the output resulting in an isolation at F2's input of -30 dB. To elevate the level of isolation for F1 a filter or a complete module tune at frequency F2 must be installed at F2's input port. This method is used to expand combiner systems and is discussed in greater detail in the next paragraph.

Balanced Combiners are easily expanded to accommodate extra stations by cascading modules. This is accomplished when the 'Combined Output' port is connected to the port in which F2 has been input of a subsequent module and in theory can be repeated an infinite number of times. The

input port for F2 is called the Wideband port due to its ability to pass a signal over the wide reject bandwidth of the filters. By the same token the input for F1 is called the Narrowband port since it will only pass a signal over the narrow pass bandwidth of the filters. The down side to expanding a combiner is the difficulty in manufacturing increases and the Insertion Loss of the channels increases each time a signal passes through a module, both resulting in more expense. A typical three channel combiner schematic is given in Figure 4.

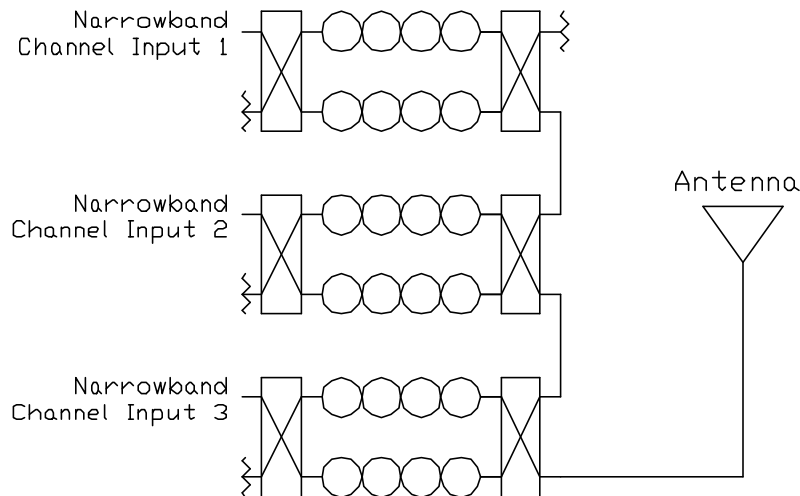

Figure 6

With a Constant Impedance Combiner the minimum channel spacing is reduced due to the increased isolation supplied by the 3-dB Hybrids. JAMPRO RF is currently developing a combiner for overseas use which will have a minimum channel spacing of 600 kHz. However, at this time the FCC mandates that the minimum channel spacing is 800 kHz. Even at 800 kHz of channel separation the channel to channel isolation with a Balanced Combiner is greater than 50 dB, typically 60 dB. The downside to such close in channel spacing is the insertion loss is increased as a result of decreasing the bandwidth to elevate out of band filter rejection and the increase in the number of sections in the filters. This reduction in system efficiency causes an increase in Transmitter Power Output to maintain the Effective Radiated Power of the broadcast system when it was a stand alone. It must be remembered that the extra cost of raising the TPO is offset through more the rise in income due to the more efficient use of tower space.

The pros and cons to each type of combiner system are numerous and must be thoroughly investigated prior to purchasing a system. The engineering staff of Jampro RF Systems, Inc. and Jampro Antenna's is always available to assist with questions pertaining to the design, layout, features and functions of combiner systems.